

Submittal Sheet

VTX400C

Inline Centrifugal Fans

Standard Features

- Supplied with mounting bracket for easy installation
 - Suitable for airstream temperatures up to 140°F
 - Aerodynamic design allowing more air flow
 - Heavy gage steel casing with a Hammertone powder coat finish, making it more sound absorbing, durable, impact resistant and rustproof
 - ETL Listed
- High quality maintenance-free balanced motor, making it vibration free, quieter and longer lasting
 - Extended collar and lip, allowing easy duct hook-up
 - Optional speed control easing air flow adjustment, allowing better balancing of the ventilation system
 - 10 year manufacturers warranty

Weight : 7.4 lbs. Metal Gauge : 18

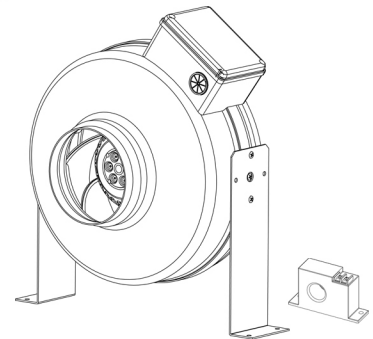
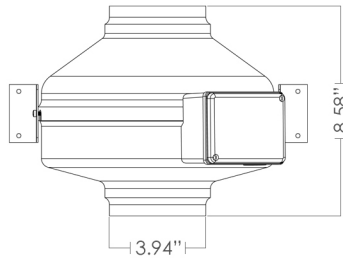
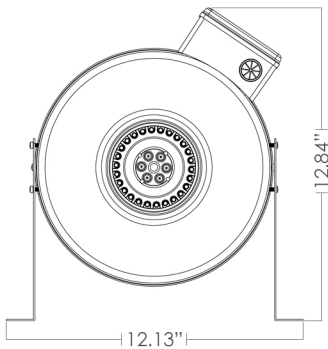

Fan Specifications						Motor Specifications			
Fan Model	Qty	CFM	SP	RPM	Sones	Watts	Volts	Phase	Hertz

Accessories	1	2	3	4	Remarks

Project _____ Submitted _____
 Customer _____ Approved _____
 Location _____